



NCS-TT106P

Profibus PA Intelligent Temperature
Transmitter

User Manual

Warning

1. It is forbidden for users to disassemble the temperature module by themselves.
2. Please check if the supply voltage of temperature transmitter meets the power supply voltage requirements in the manual.

Disclaimer

The contents of this manual have been checked to confirm the consistency of the hardware and software described. Since errors cannot be completely ruled out, absolute consistency cannot be guaranteed. However, we will regularly check the data in this manual and make necessary corrections in subsequent versions. Any suggestions for improvement are welcome.

Microcyber Corporation 2020

Technical data is subject to change.

Company Introduction

Microcyber Corporation, established as a high-tech enterprise by the Shenyang Institute of Automation Chinese Academy of Sciences, mainly engages in advanced industrial control systems, equipments, instruments and chips for industrial process automation control solutions in the research, development, production and application. Microcyber undertakes a number of national scientific and technical key task and “863” project, and has Liaoning Province networked control systems engineering research center.

Microcyber successfully developed the FF H1 fieldbus protocol stack which is number one to be approved internationally in China, and the Industrial Ethernet Protocol(HSE) which is number one to be approved in China, and the domestic first fieldbus instrument which has a function of national-level intrinsically safe explosion--proof and safety barrier. Also Microcyber participated in the drafting of the domestic first Ethernet-based industrial automation protocol standards (Ethernet for Plant Automation, EPA). As a result, serial products are composed of configuration, control software, embedded software, control system, instrument chip to the OEM board, and make Microcyber be an industrial automation products provider in full range, and also further Microcyber’s leading position in the field of fieldbus technology.

Microcyber is the member of FieldComm Group(FCG) and Profibus National Organization (PNO) .

Microcyber passes the Authentication of ISO 9001 Quality System, and has an outstanding innovative R&D team, plentiful practical experiences of design of the Automatic engineering, a leading product series, a huge market network, a strict quality management system and an excellent enterprise culture. All these further a solid foundation of entrepreneurship and sustainable development for Microcyber.

Carrying the ideals of employees, creating customer value and promoting enterprise development.

CATALOGUE

1	OVERVIEW	1
2	TEMPERATURE TRANSMITTER INSTALLATION	2
2.1	DIMENSIONS.....	2
2.2	INSTALLATION.....	2
2.3	WIRING	4
3	PROFIBUS PA PROTOCOL TEMPERATURE TRANSMITTER CONFIGURATION	5
3.1	TOPOLOGY CONNECTION.....	5
3.2	FUNCTION BLOCK.....	6
3.3	FUNCTION CONFIGURATION	6
3.3.1	Configuration environment	6
3.3.2	Introduction to temperature transducer block parameters	6
3.3.3	PROFIBUS cyclic data communication configuration.....	11
3.3.4	PROFIBUS acyclic data communication configuration	14
3.3.5	Configure the function.....	16
3.3.6	Modify the main parameters of the device through GSD file.....	20
4	MAINTENANCE	24
5	TECHNICAL SPECIFICATIONS	25
5.1	BASIC PARAMETERS	25
5.2	THERMAL RESISTANCE TECHNICAL INDEX	25
5.3	THERMOCOUPLE TECHNICAL INDICATORS	26
5.4	PHYSICAL CHARACTERISTICS	26

1 Overview

NCS-TT106P intelligent temperature transmitter adopts field bus technology, is a new generation of intelligent temperature transmitter, is an indispensable field device in process control. The device integrates a wealth of functional modules, which can achieve both general detection functions and complex control strategies.

NCS-TT106P adopts digital technology and can be applied to a variety of thermal resistance and thermocouple sensors. It has a wide measuring range and a simple interface between the field and the control room.

NCS-TT106P intelligent temperature transmitter supports Profibus PA protocol, which can be widely used in petroleum, chemical, electric power, metallurgy and other industries.

2 Temperature transmitter installation

2.1 Dimensions

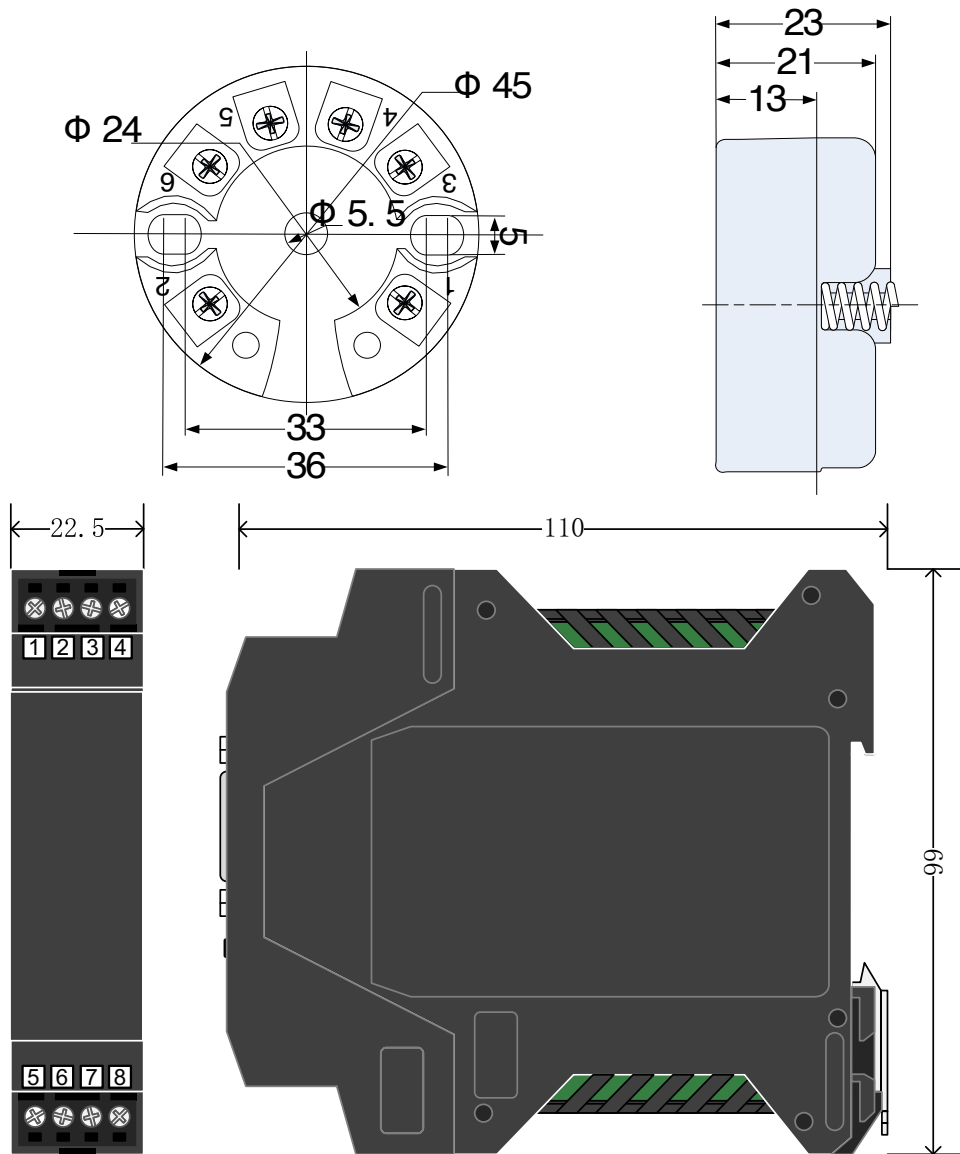

NCS-TT106P-R1

Figure 错误!文档中没有指定样式的文字。 .1 Dimension of Temperature Transmitter (Unit: mm)

2.2 Installation

Fix the temperature transmitter into the temperature housing or guide rail by positioning the two screws through the positioning hole.

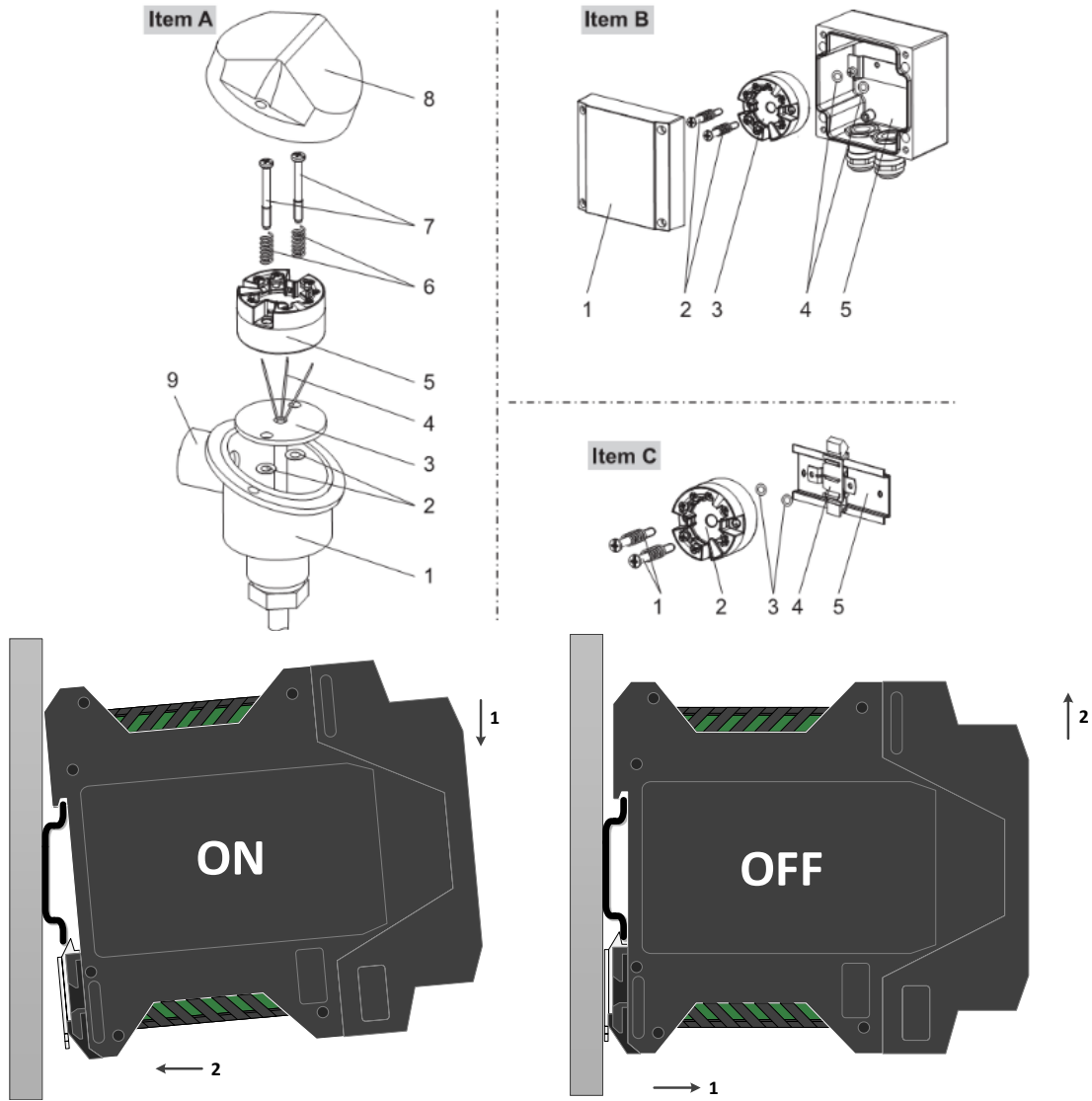

Figure 错误!文档中没有指定样式的文字。 .2 Installation

2.3 Wiring

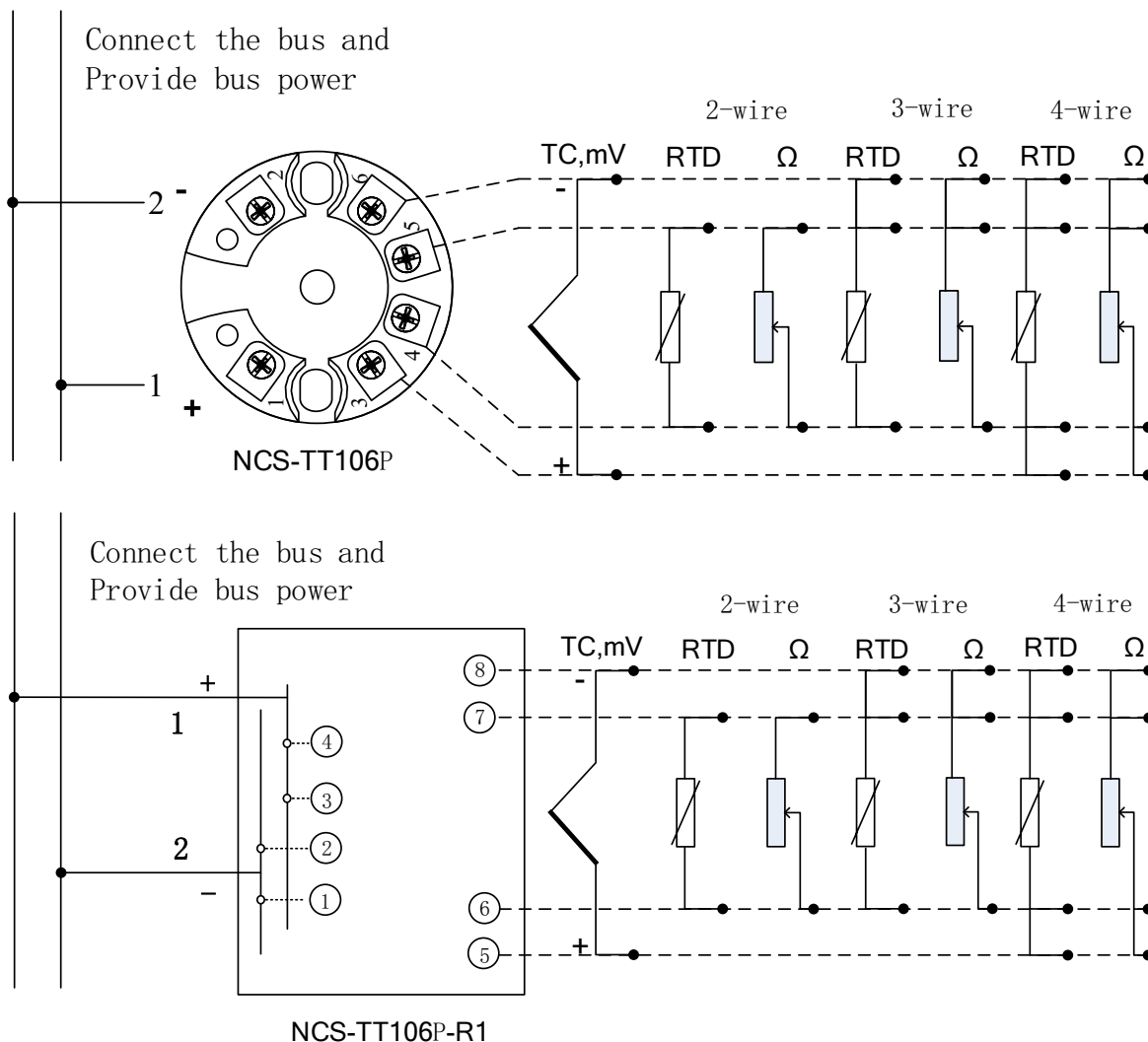

Figure 错误!文档中没有指定样式的文字。 .3 Wiring

The power supply of NCS-TT106P temperature transmitter and bus signal share a pair of cables, called bus cable. It is recommended to use the fieldbus dedicated cable recommended by IEC61158-2. The signal cable and bus cable should not share the conduit or open channel with the power cables of other equipment, and should be far away from high-power equipment. The shielded wires at both ends of the bus are grounded by single-ended grounding.

3 Profibus PA Protocol Temperature Transmitter Configuration

3.1 Topology Connection

A PROFIBUS PA supports multiple network topology wiring methods, as shown in Figure 错误!文档中没有指定样式的文字。 .4 Figure 错误!文档中没有指定样式的文字。 .5 shows the bus connection of the FOUNDATION FIELDBUS transmitter. Both ends of the bus need to be connected with terminal matching resistors to ensure signal quality. The maximum length of the bus is 1900 meters, and it can be extended to 10 kilometers by using repeaters.

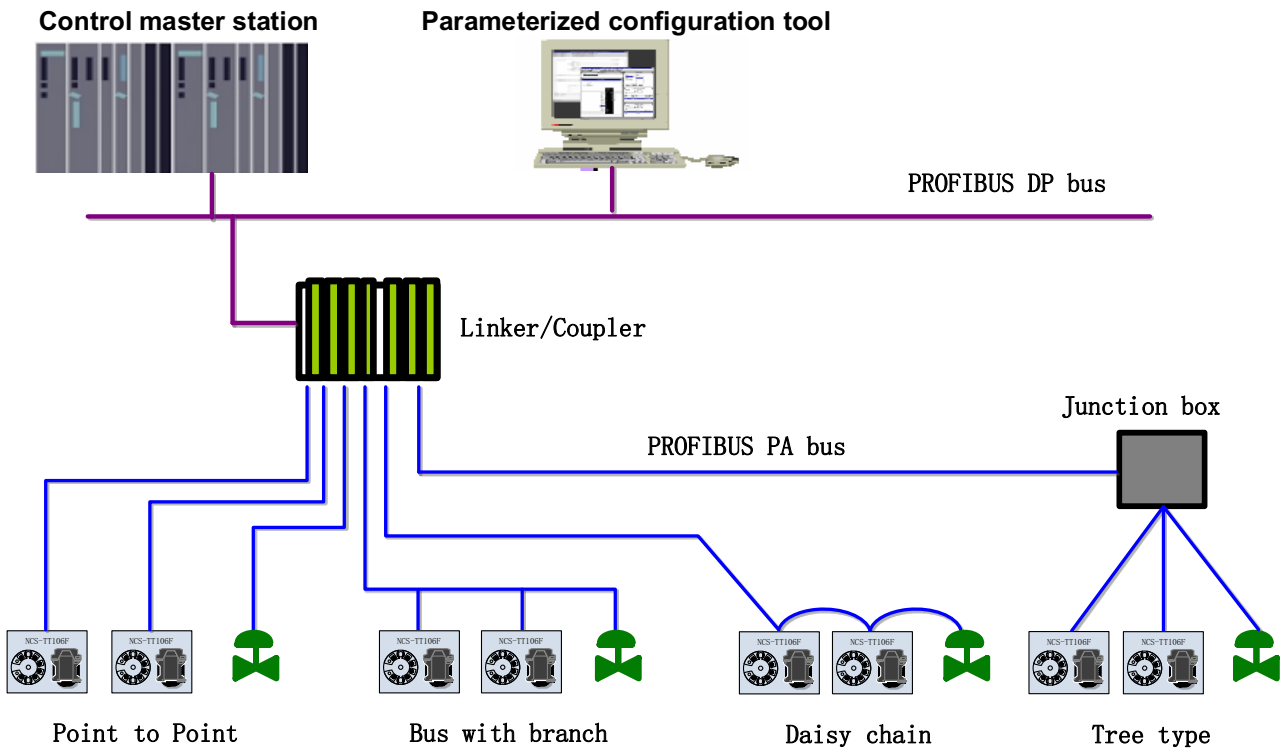

Figure 错误!文档中没有指定样式的文字。 .4 PROFIBUS PA network topology

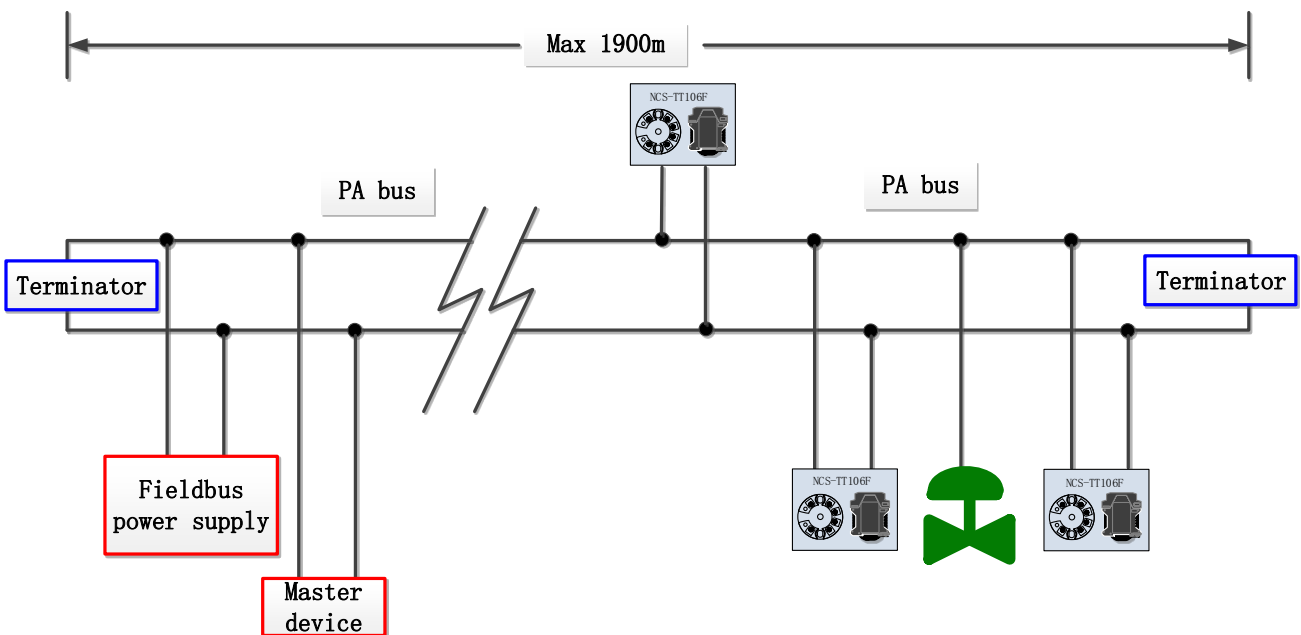

Figure 错误!文档中没有指定样式的文字。 .5 PROFIBUS PA bus connection

3.2 Function block

PA temperature transmitter implements the PA standard function block, see the table below. For the configuration method of the function block, please refer to the PROFIBUS PA protocol related documents.

Name	Description
Physical Block	Physical function block (PB). Describes the unique hardware information and identification and diagnostic information of the device, including device tag number, software version, hardware version, installation date, etc.
Transducer Block 1	Transducer block 1 (TB 1). It mainly completes the calibration and linearization of input and output data, and provides the processed data to the AI function block through the internal channel.
Transducer Block 2	Transducer block 2 (TB 2). Expand the function of transducer block 1, mainly to complete the user secondary calibration and user-defined sensor type functions.
Analog Input Block 1	Analog Input function block 1 (AI 1). Obtain the analog process value from the transducer block through the internal channel, process it, and provide the appropriate measured value to the master device through bus communication.
Analog Input Block 2	Analog Input function block 2 (AI 2). Obtain the ambient temperature value from the transducer block through the internal channel and process it, and provide the appropriate measured value to the master device through bus communication.

3.3 Function configuration

The parameter configuration of the PA intelligent temperature transmitter follows the PROFIBUS PA profile 3.02 version. You can use Siemens' equipment management software Simatic PDM to read and write the function block parameters of the temperature transmitter, or you can use Siemens' STEP7 configuration software to configure the temperature transmitter.

3.3.1 Configuration environment

- 1) PC, the operating system is Windows 2000 or Windows XP;
- 2) Siemens STEP7 configuration software, Siemens PDM equipment management software;
- 3) DP/PA coupler or linker;
- 4) Type 1 master station such as PLC, Type 2 master station such as CP5611 card;
- 5) PA terminal matcher;
- 6) Standard temperature source.

3.3.2 Introduction to temperature transducer block parameters

Transducer block separates functional blocks from physical proprietary I/O devices such as sensors and actuators. It depends on the implementation of the device manufacturer to access or control I/O devices. By accessing I/O devices, the transducer block can obtain input data or set output data. Generally, the transducer block has functions such as linearization, characterization, temperature compensation, control and data exchange. The structure of the transducer block is shown in Figure 3.3.

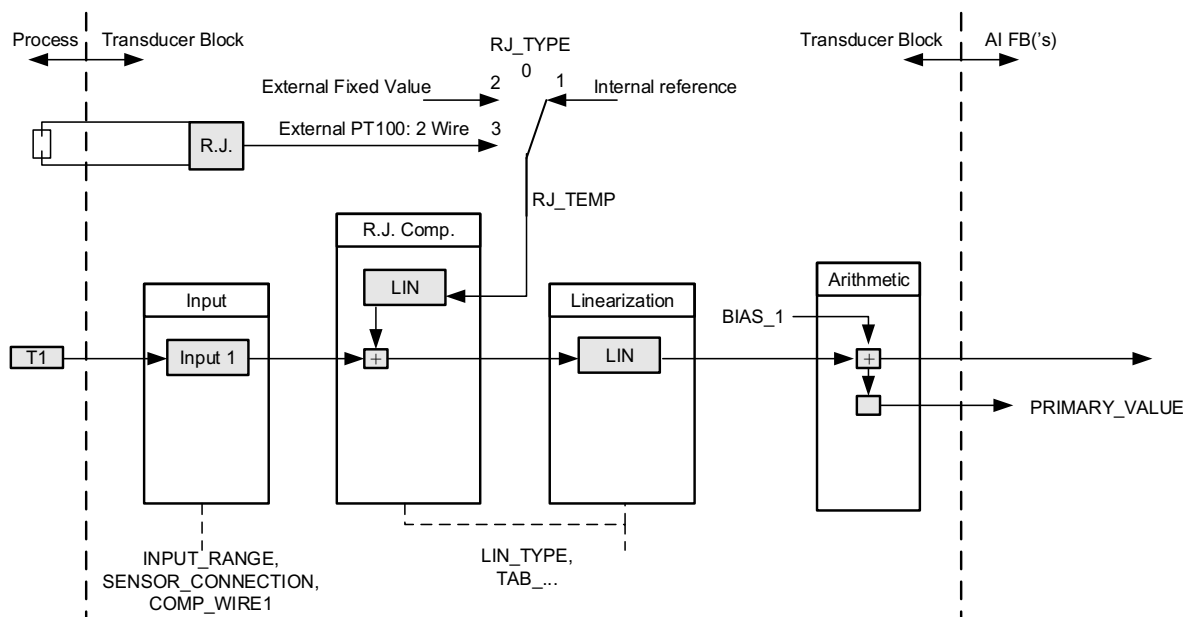

Figure 3.3 Transducer block structure

The parameters of the transducer block are shown in the following table:

Parameter	Name in EDD	Function description
INPUT_FAULT_GEN	Input Malfunction	Input failure: error diagnosis object containing all values. 0: The device is normal Bit 0: RJ error Bit 1: Hardware error Bit 2-4: Reserved Bit 5: Manufacturer specified Bit 6: Communication error Bit 7: Manufacturer specified
INPUT_FAULT_1	Channel 1 fault	Input failure: SV_1 related error diagnosis object. 0: Input is normal Bit 0: Above the upper limit range Bit 1: Below the lower limit range Bit 2: Open circuit Bit 3: Short circuit Bit 4: Below the lower limit of cold junction temperature Bit 5: Above the upper limit of cold junction temperature Bit 6: AD error Bit 7: Reserved
BIAS_1	Offset	Channel 1 process variable deviation value. The unit is specified by PRIMARY_VALUE_UNIT.
INPUT_RANGE	Input Range and Mode	0: mV range 1 => mV 100 128: Ω range 1 => Ohm 500 129: Ω range 2 => Ohm 4000
LIN_TYPE	Characterization Type	Linearization type.
SENSOR_WIRE_CHECK_1	Sensor wire check_1	Enable open circuit detection or short circuit detection. The encoding is as follows: 0: Both open circuit detection and short circuit detection are enabled; 1: Open circuit detection is enabled, short circuit detection is prohibited; 2: Open circuit detection prohibited, short circuit detection enabled 3: Both open circuit detection and short circuit detection

Parameter	Name in EDD	Function description
		are prohibited.
PRIMARY_VALUE	Measured Value	Temperature transmitter measurement value and status. The unit is specified by PRIMARY_VALUE_UNIT.
PRIMARY_VALUE_UNIT	Unit	Engineering unit code of temperature transmitter measurement value.
UPPER_SENSOR_LIMIT	Upper Value Max	Physical upper limit of the sensor.
LOWER_SENSOR_LIMIT	Lower Value Max	Physical lower limit of the sensor.
SECONDARY_VALUE_1(SV_1)	Channel 1	Process value and status from channel 1 corrected by BIAS_1. The unit is specified by PRIMARY_VALUE_UNIT.

Additional parameters of thermocouple are shown in the table below:

Parameter	Name in EDD	Function description
EXTERNAL_RJ_VALUE	Ext. Reference Junction Temperature	External reference point temperature. Can be entered manually by the user. The unit is specified by PRIMARY_VALUE_UNIT. If the unit of PRIMARY_VALUE_UNIT is not a temperature unit (for example: mV), the unit is set to °C.
RJ_TEMP	Reference Junction Temperature	Reference point temperature. The unit is specified by PRIMARY_VALUE_UNIT. If the unit of PRIMARY_VALUE_UNIT is not a temperature unit (for example: mV), the unit is set to °C.
RJ_TYPE	Reference Junction	Set the reference point type. The encoding is as follows: 0: No reference, no compensation; 1: Internal, the reference point temperature of the equipment self-test; 2: External, the reference point temperature from the outside; 3: The reference point temperature measured by an external PT100; 1 is selected by default.

The additional parameters of thermal resistance are shown in the table below:

Parameter	Name in EDD	Function description
SENSOR_CONNECTION	Connection Type	Can choose 2, 3, 4-wire to connect with the sensor. 0: 2-wire ; 1: 3-wire; 2: 4-wire.

The manufacturer-defined parameters are shown in the table below:

Parameter	Name in EDD	Function description
SENSOR_VALUE_1	Channel 1 Sensor Value	Sensor 1 raw data value.
CAL_POINT_HI	Upper Calibration Point	The highest point calibration value. The unit is specified by CAL_UNIT.
CAL_POINT_LO	Lower Calibration Point	The lowest point calibration value. The unit is specified by CAL_UNIT.

Parameter	Name in EDD	Function description
CAL_MIN_SPAN	Calibration Span Min	The minimum step size allowed during calibration. The minimum step length ensures the smooth progress of the calibration process, so that the distance between the highest and lowest points of the calibration is not too close, and the unit is specified by CAL_UNIT.
CAL_UNIT	Calibration Unit	Calibration unit. Currently only three units of Celsius, Ohm and Millivolt are supported.
COMPENSATION	Compensation	Zero point compensation. It is used for zero point compensation of 2-wire and PT100 cold junction compensation of thermocouple.
RO_ADJUST	R0 Adjust	Used to calibrate the sensor connected to the temperature transmitter.
CUSTOM_TC_NAME	Name	Used to store the name of the user-defined TC type.
CUSTOM_TC_POLY_COUNT	Number of Polynomials	Number of user-defined TC type Polynomials: 1 ~ 5
CUSTOM_TC_MIN_IN	Lower x-Value	The minimum input value of user-defined TC type (x).
CUSTOM_TC_MIN_OUT	Lower y-Value	The minimum output value of user-defined TC type (y).
CUSTOM_TC_MAX_OUT	Upper y-Value	The maximum output value of user-defined TC type (y).
CUSTOM_TC_POLY1	Upper x-Value 0th Order: constant a 1th Order: b 2th Order: c 3th Order: d 4th Order: e	The first group of user-defined TC type polynomial coefficients consists of 6 data: The upper limit of the first segment is x^0 coefficient a, x^1 coefficient b, x^2 coefficient c, x^3 coefficient d, x^4 coefficient e.
CUSTOM_TC_POLY2	Upper x-Value 0th Order: constant a 1th Order: b 2th Order: c 3th Order: d 4th Order: e	The second group of user-defined TC type polynomial coefficients consists of 6 data: The second upper limit, x^0 coefficient a, x^1 coefficient b, x^2 coefficient c, x^3 coefficient d, x^4 coefficient e.
CUSTOM_TC_POLY3	Upper x-Value 0th Order: constant a 1th Order: b 2th Order: c 3th Order: d 4th Order: e	The third group of user-defined TC type polynomial coefficients consists of 6 data: The third upper limit, x^0 coefficient a, x^1 coefficient b, x^2 coefficient c, x^3 coefficient d, x^4 coefficient e.

Parameter	Name in EDD	Function description
CUSTOM_TC_POLY4	Upper x-Value 0th Order: constant a 1th Order: b 2th Order: c 3th Order: d 4th Order: e	The fourth group of user-defined TC type polynomial coefficients consists of 6 data: The upper limit of the fourth paragraph, x^0 coefficient a, x^1 coefficient b, x^2 coefficient c, x^3 coefficient d, x^4 coefficient e.
CUSTOM_TC_POLY5	Upper x-Value 0th Order: constant a 1th Order: b 2th Order: c 3th Order: d 4th Order: e	The fifth group of user-defined TC type polynomial coefficients consists of 6 data: The upper limit of the fifth paragraph, x^0 coefficient a, x^1 coefficient b, x^2 coefficient c, x^3 coefficient d, x^4 coefficient e.
CUSTOM_TC_RJ_POLY	0th Order: constant a 1th Order: b 2th Order: c 3th Order: d	User-defined TC type cold junction temperature polynomial coefficient, a total of 4 data components: x^0 coefficient a, x^1 coefficient b, x^2 coefficient c, x^3 coefficient d.
CUSTOM_RTD_NAME	Name	Used to store the name of the user-defined RTD type.
CUSTOM_RTD_POLY_COUNT	Number of Polynomials	Number of user-defined RTD polynomials: 1~5
CUSTOM_RTD_MIN_IN	Lower x-Value	The minimum input value of user-defined RTD type (x).
CUSTOM_RTD_MIN_OUT	Lower y-Value	The minimum output value of user-defined RTD type (y).
CUSTOM_RTD_MAX_OUT	Upper y-Value	The maximum output value of user-defined RTD type (y).
CUSTOM_RTD_POLY1	Upper x-Value 0th Order: constant a 1th Order: b 2th Order: c 3th Order: d 4th Order: e	The first group of user-defined RTD type polynomial coefficients consists of 6 data: The upper limit of the first paragraph, x^1 coefficient b, x^2 coefficient c, x^3 coefficient d, x^4 coefficient e.
CUSTOM_RTD_POLY2	Upper x-Value 0th Order: constant a 1th Order: b 2th Order: c 3th Order: d 4th Order: e	The second group of user-defined RTD type polynomial coefficients consists of 6 data: The upper limit of the second paragraph, x^1 coefficient b, x^2 coefficient c, x^3 coefficient d, x^4 coefficient e.
CUSTOM_RTD_POLY3	Upper x-Value 0th Order: constant a 1th Order: b	The third group of user-defined RTD type polynomial coefficients consists of 6 data: The upper limit of the third paragraph, x^1 coefficient b, x^2

Parameter	Name in EDD	Function description
	2th Order: c 3th Order: d 4th Order: e	coefficient c,x ³ coefficient d,x ⁴ coefficient e.
CUSTOM_RTD_POLY4	Upper x-Value 0th Order: constant a 1th Order: b 2th Order: c 3th Order: d 4th Order: e	The fourth group of user-defined RTD type polynomial coefficients consists of 6 data: The upper limit of the fourth paragraph, x ¹ coefficient b,x ² coefficient c,x ³ coefficient d,x ⁴ coefficient e.
CUSTOM_RTD_POLY5	Upper x-Value 0th Order: constant a 1th Order: b 2th Order: c 3th Order: d 4th Order: e	The fifth group of user-defined RTD type polynomial coefficients consists of 6 data: The upper limit of the fifth paragraph, x ¹ coefficient b,x ² coefficient c,x ³ coefficient d,x ⁴ coefficient e.
TAB_ENTRY	TAB Entry	The index of the current selection in the calibration table.
TAB_X_Y_VALUE	X Y	The value of the currently selected item in the calibration table (x, y)
TAB_MIN_NUMBER	Min Number	The minimum number of points in the calibration table.
TAB_MAX_NUMBER	Max Number	The maximum number of points in the calibration table.
TAB_OP_CODE	OP code	The operation method of calibration table.
TAB_STATUS	Status	The operation status of calibration table.
TAB_ACTUAL_NUMBER	Tab actual number	The actual number of points in the calibration table.

3.3.3 PROFIBUS cyclic data communication configuration

The cyclic data communication of PROFIBUS DP refers to the type 1 master station and the slave station to exchange input and output data in a master-slave polling manner, and the communication method is a connectionless. In each cycle, the Type 1 master station actively sends a data exchange request, and the slave station passively responds to the request of the master station. Cyclic data communication is mainly used in the configuration of slave station and PLC master station equipment. Through cyclic data communication, the master station PLC obtains the input data of the slave station or outputs the output data to the slave station in real time.

The cyclic data communication configuration of the PA type intelligent temperature transmitter is basically the same as that of the PROFIBUS DP slave, but a coupler or linker is required between the PA bus and the DP bus.

The cyclic data of the PA type intelligent temperature transmitter comes from the output parameters of the AI function block in the device, and each AI function block output parameter has 5 bytes.

The output of AI function block 1 includes 4 bytes of floating point data of measured temperature value and 1 byte of status data.

The output of AI function block 2 includes 4 bytes of floating point data of ambient temperature value and 1 byte of status data.

For cyclic communication, the temperature transmitter supports two types of AI function block identifiers, namely short AI identifier 0x94 and long AI identifier 0x42, 0x84, 0x08, 0x05. Null identifiers are also supported. The PA type intelligent temperature transmitter has two slots, and each slot can choose three identifiers.

You can use Siemens STEP7 to configure PROFIBUS PA for cyclic data communication.

The following gives an example of using Siemens STEP7 to configure a PA temperature transmitter.

Open SIMATIC Manager, follow the prompts to select the PLC master station and create a new project, as shown in Figure 3.4.

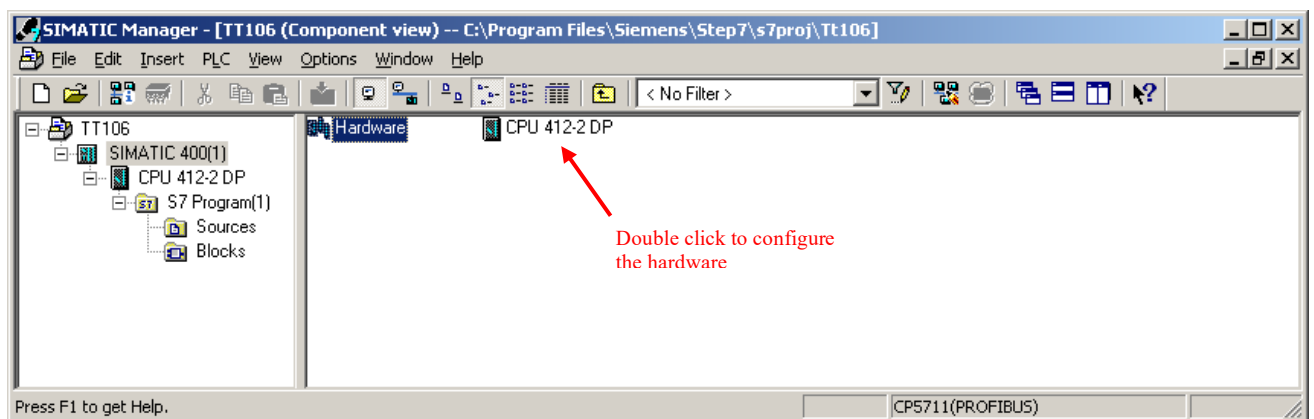

Figure 3.4 Select PLC master station and create a new project

Double-click Hardware to check the HW Config software hardware configuration. Select Install GSD in the Option menu to install the GSD file of the PA temperature transmitter, as shown in Figure 3.5.

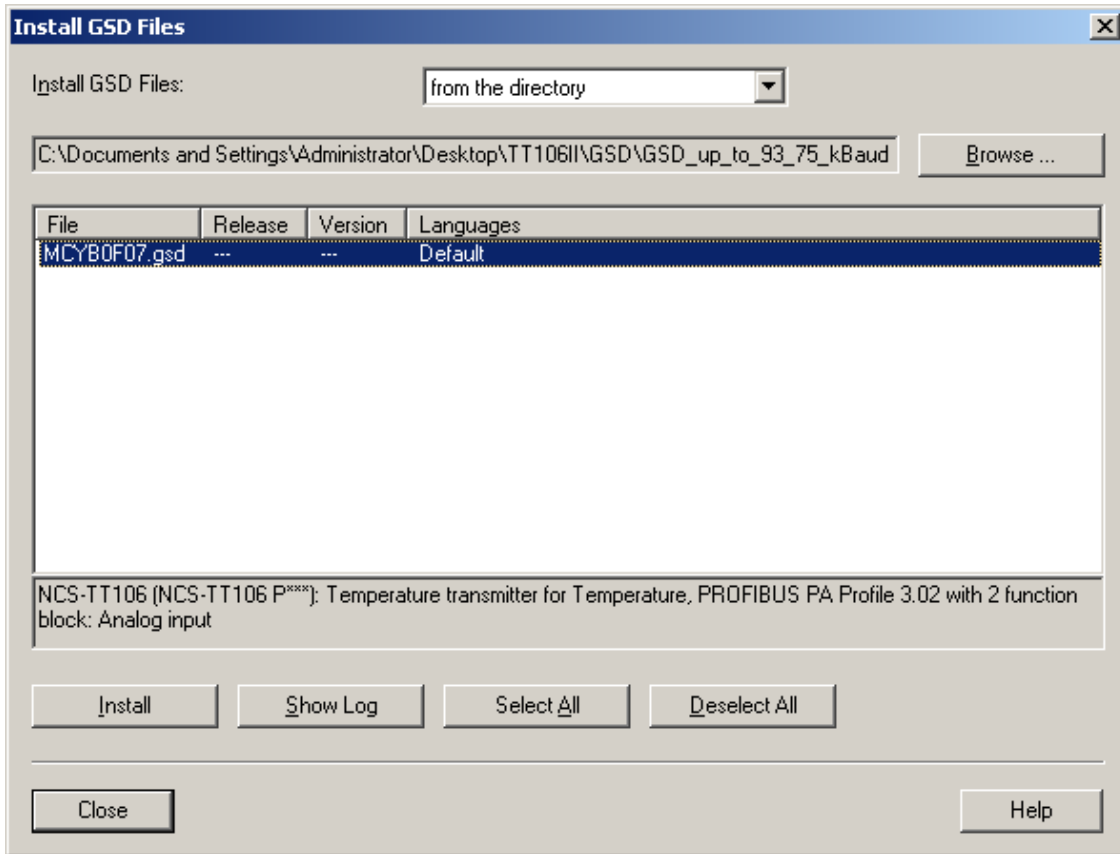

Figure 3.5 Install GSD file

After the GSD file is successfully installed, the PA device just installed will be listed in the Temperature series of Microcyber Control in the PROFIBUS-PA category in the device list on the right side of the HW Config software. Use the mouse to select it and drag it to the PROFIBUS DP bus, as shown in Figure 3.6.

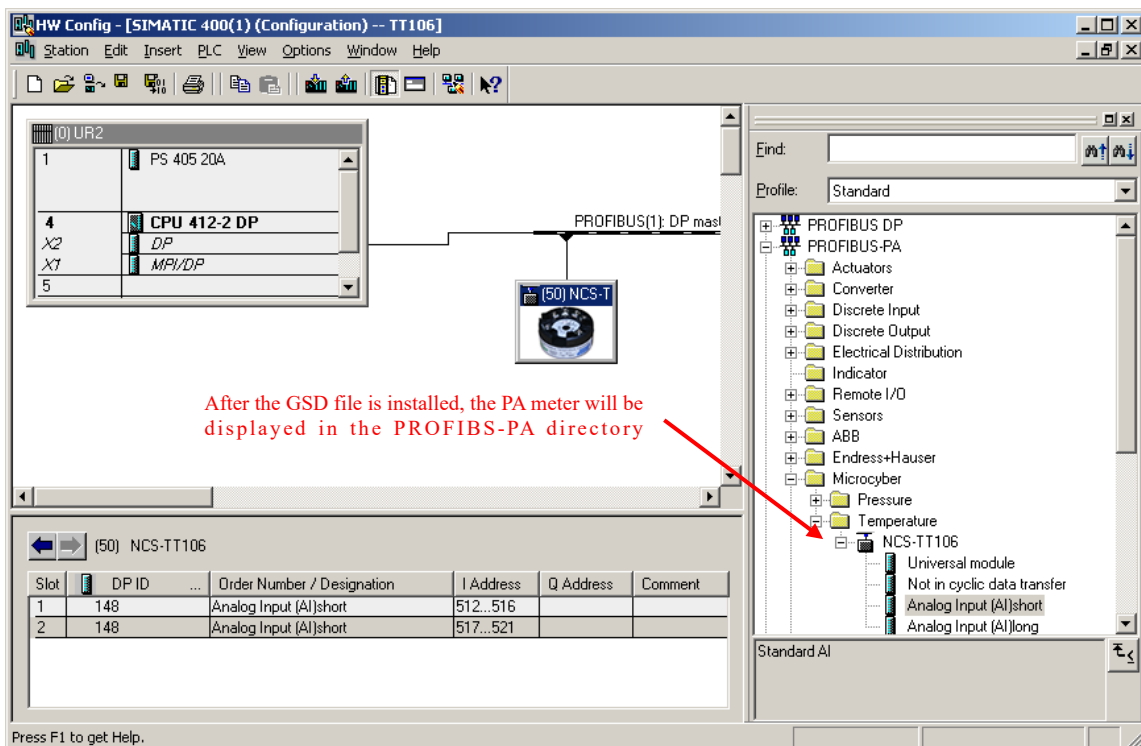

Figure 3.6 Drag the PA device to the PROFIBUS DP bus

Select Download in the PLC menu to download the configuration information to the PLC master station. This

completes the cyclic data communication configuration between the PA instrument and the master station, as shown in Figure 3.7.

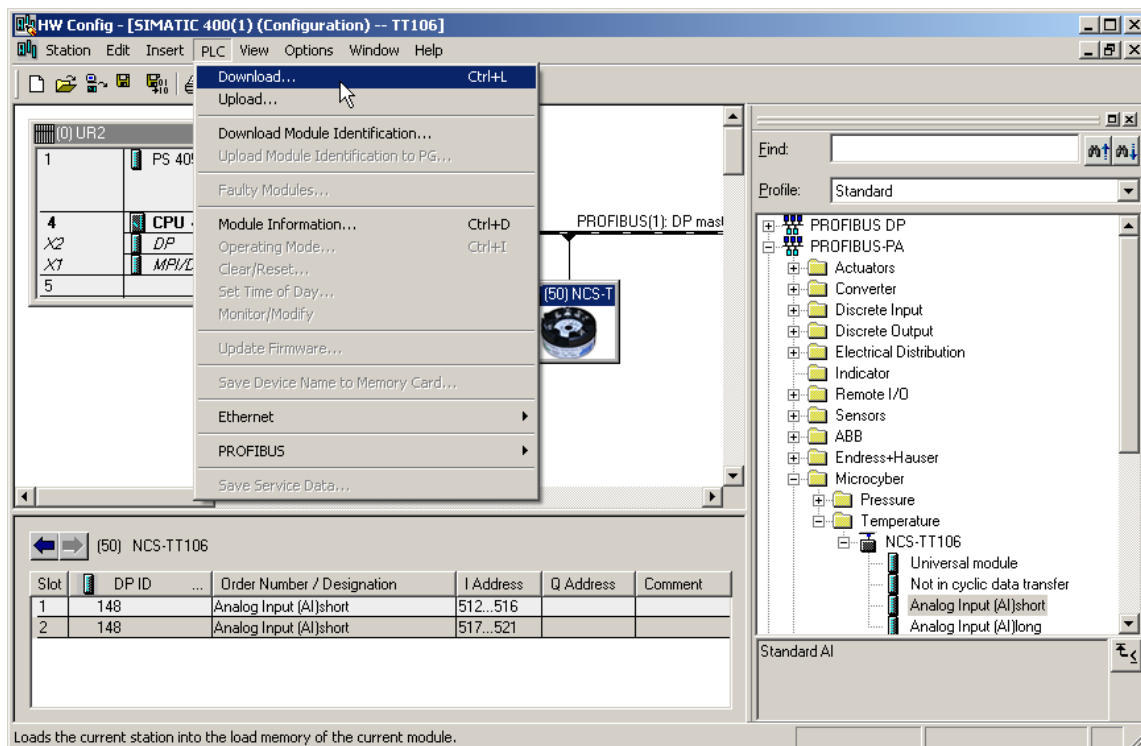

Figure 3.7 Download configuration information to PLC

3.3.4 PROFIBUS acyclic data communication configuration

The acyclic data communication of PROFIBUS DP refers to the connection-oriented data communication carried out between the 2 types of master stations and slave stations. This data communication is carried out in the acyclic period of the bus without affecting the cyclic data communication. The acyclic data is mainly the parameters of PA function blocks and the identification and diagnosis information of the device. Acyclic data communication is mainly used in the management, diagnosis, identification, adjustment and maintenance of PA device.

The acyclic data communication configuration of PA instrument can be carried out through Siemens' equipment management software SIMATIC PDM.

The following gives an example of using SIMATIC PDM to carry out acyclic communication configuration on the PA type intelligent temperature transmitter.

Open the Manage Device catalog software attached to SIMATIC PDM, select the EDD file of TT306P and import it, as shown in Figure 3.8.

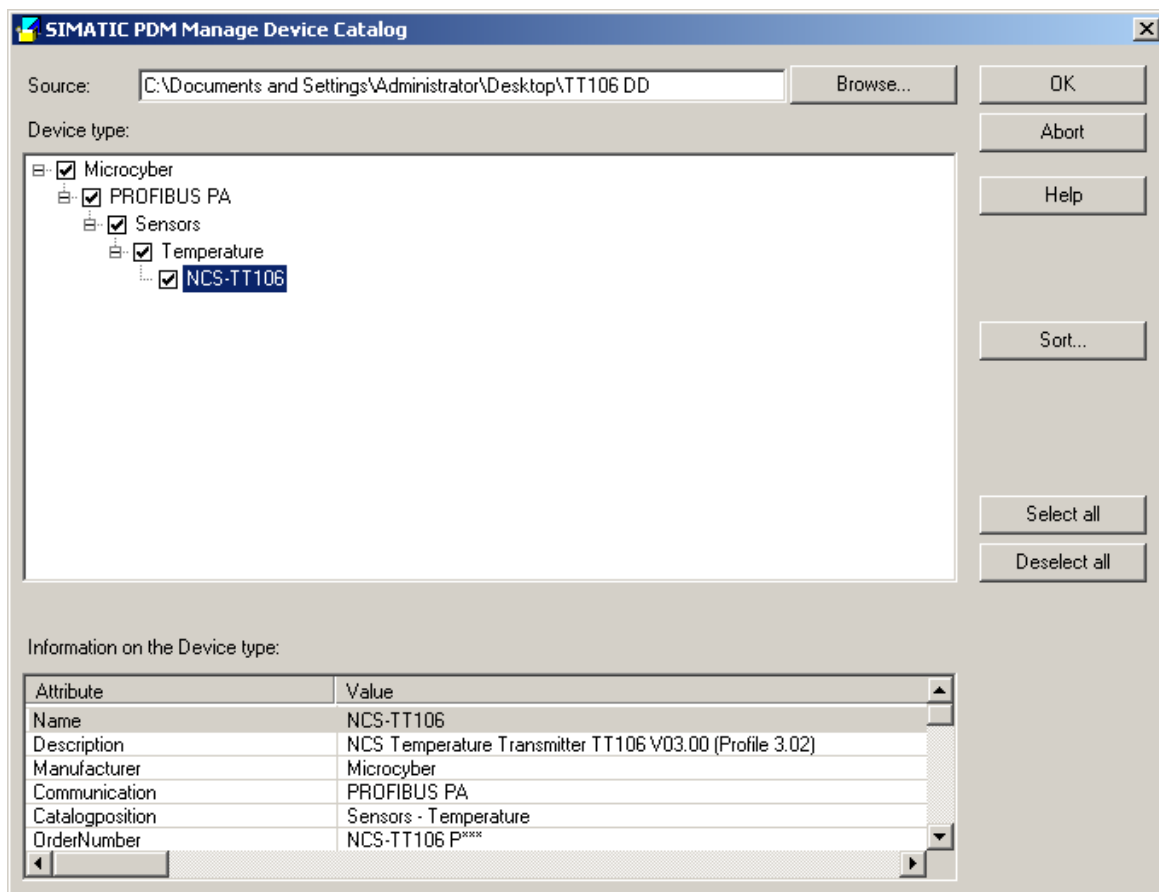

Figure 3.8 Select device type

Open the LifeList software attached to SIMATIC PDM, select Start under the Scan menu to scan the DP bus, as shown in Figure 3.9.

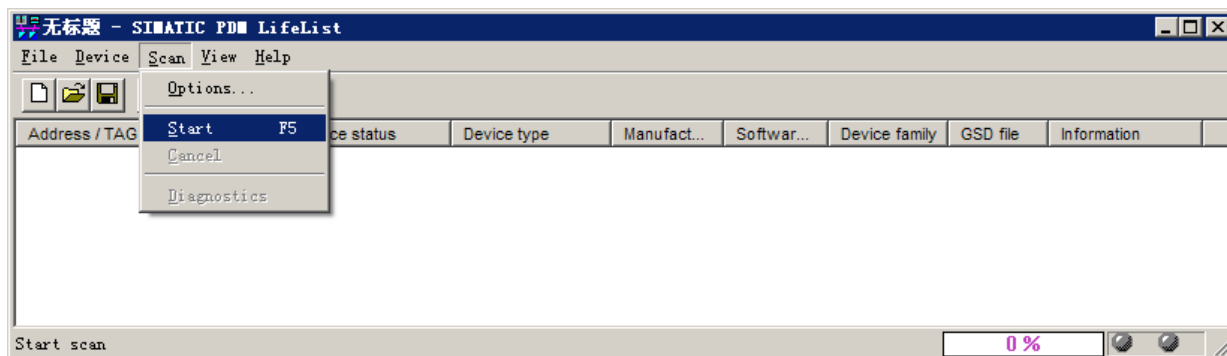

Figure 3.9 Start LifeList

After scanning the bus, the slave devices on the DP bus will be listed, and the manufacturer ID number and some diagnostic information of the device will be displayed at the same time, as shown in Figure 3.10.

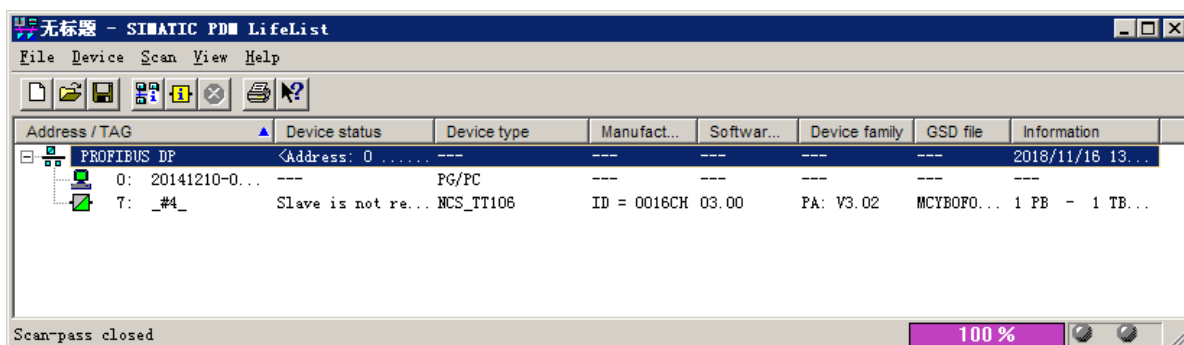

Figure 3.10 Scan DP bus to list PA devices

After selecting the device type, click OK, so that the acyclic data communication is configured. Through the upload and download functions of the PDM software, the parameter reading and writing of the PA instrument can be completed, as shown in Figure 3.11.

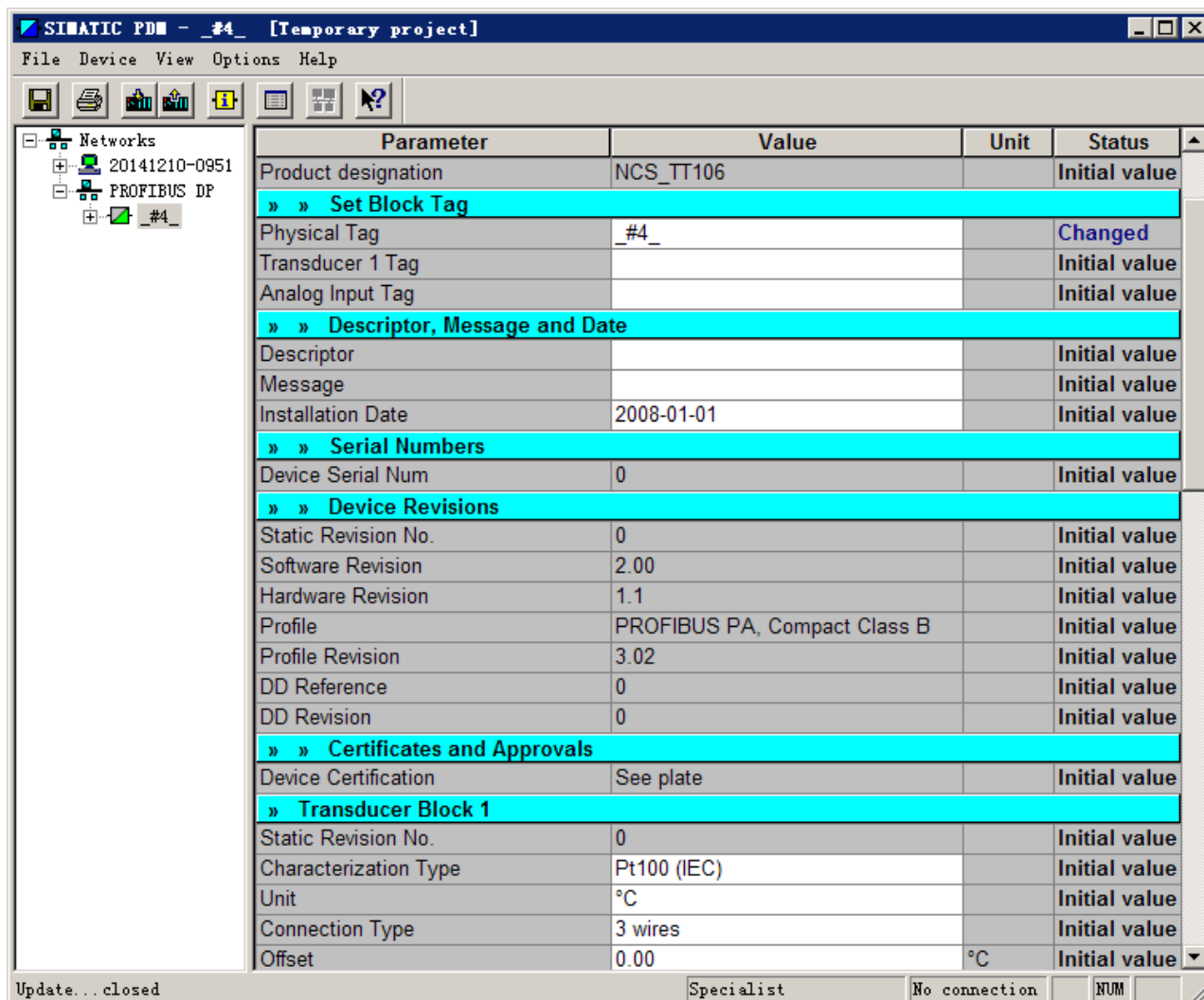

Figure 3.11 Use PDM software for device management

Note: When using PDM software for parameter configuration, due to the unit association between some parameters, you need to modify the unit configuration before modifying the parameter value configuration, so as not to affect the correct configuration of the parameters.

3.3.5 Configure the function

The PA type intelligent temperature transmitter implements PA standard function blocks. Through the PDM software, after configuration, select Device -> Configuration to operate the transducer block or AI function block parameters.

(1) Sensor type configuration

You can set the sensor type, such as PT100, CU50, etc., by modifying the Characterization Type and Input Range and Mode parameters of the transducer block. When the Characterization Type parameter is Linear, the Input Range

and Mode parameters are valid.

(2) Two-wire zero calibration configuration

In the two-wire system measurement, the two-wire system zero point calibration can be performed. First give the channel zero value, that is, short-circuit the end of the cable connected to the sensor. Then open the PDM software, after configuration, select Device -> Configuration -> Transducer Block 1, and set the two-wire calibration function in the Set 2-Wire Compensation box in Advanced Settings.

Click the Write button, when the Finished dialog box appears, it indicates that the two-wire system zero calibration is successful;

Click the Reset button. When the Finished dialog box appears, it indicates that the two-wire system zero calibration is successfully reset.

(3) Enable cold junction temperature compensation

When using a thermocouple as a sensor, the transducer block Reference Junction Temperature parameter represents the cold junction temperature value, and the Primary Value represents the temperature value of the measuring junction relative to the cold junction. If the Primary Value is required to output a measurement value relative to 0 degrees (ie, the cold junction temperature is 0 degrees), it can be achieved by setting the Reference Junction parameter.

When the Reference Junction parameter is set to Internal measured reference junction, the cold junction temperature is the internal collected value of NCS-TT106P;

When the Reference Junction parameter is set to External Fixed Value, the cold junction temperature is the Ext Reference Junction Temperature value;

When the Reference Junction parameter is set to External PT100: 2 Wire, the cold junction temperature is the collected value of the NCS-TT106P external two-wire PT100.

By default, the cold junction temperature compensation Reference Junction parameter is set to Internal measured reference junction.

(4) External PT100: 2-Wire zero point calibration configuration

When using a thermocouple as a sensor, when the External PT100: 2-wire cold junction compensation method is selected, the two-wire zero point calibration of the external PT100 cold junction compensation method can be performed. First, set the zero point value of the external PT100 channel, that is, short the cable end connected to the external PT100. Then open the PDM software, after configuration, select Device -> Configuration -> Transducer Block 1, and set the External PT100: 2-wire cold junction compensation method 2-wire calibration function in the Select Reference Junction Type box in Basic Settings.

Click the Write button, when the Finished dialog box appears, it indicates that the two-wire zero point calibration of the external PT100 cold junction compensation method is successful;

Click the Reset button, when the Finished dialog box appears, it indicates that the two-wire zero point calibration data of the external PT100 cold junction compensation method has been successfully cleared.

(5) Custom TC sensor type

When the Characterization Type selects Custom defined TC, multiple sets of custom linear polynomials will appear.

Fill in the appropriate polynomial coefficients and ranges to complete a custom TC type. For example:

CUSTOM_TC_NAME	Custom TC Example
CUSTOM_TC_POLY_COUNT	5
CUSTOM_TC_MIN_IN	-6500.0
CUSTOM_TC_MIN_OUT	-100.0
CUSTOM_TC_MAX_OUT	1200.0

Example of custom TC sensor polynomial coefficients

CUSTOM_TC_POLY_X	max.input limit in μV for POLY_X	4th degree coefficient for POLY_X	3th degree coefficient for POLY_X	2th degree coefficient for POLY_X	1st degree coefficient for POLY_X	0degree coefficient for POLY_X
CUSTOM_TC_POLY_1	-3200.0	-3.84E-13	-5.65E-9	-3.36E-5	-6.10E-2	-8.44E1
CUSTOM_TC_POLY_2	3500.0	-8.13E-15	7.29E-11	-4.18E-7	2.53E-2	-1.08E-2
CUSTOM_TC_POLY_3	10000.0	-1.35E-15	1.50E-11	1.41E-7	2.26E-2	4.18
CUSTOM_TC_POLY_4	30000.0	3.49E-18	2.19E-12	-1.53E-7	2.68E-2	-9.26
CUSTOM_TC_POLY_5	70000.0	6.27E-17	-8.76E-12	5.34E-7	8.69E-3	1.65E2

	3th degree coefficient	2th degree coefficient	1st degree coefficient	0 degree coefficient
CUSTOM_TC_RJ_POLY	-1.11E-4	2.65E-2	3.94E1	3.94E-1

For example, if the input voltage at the TC terminal of the temperature transmitter is 5000 μV and the cold junction temperature is 25 $^{\circ}\text{C}$, the voltage value corresponding to the cold junction temperature can be calculated according to the formula:

$$U_{RJ} = 3.94 * 10^{-1} + 3.94 * 10^1 * 25 + 2.65 * 10^{-2} * 25^2 - 1.11 * 10^{-4} * 25^3 = 1000 \mu\text{V}$$

Add this voltage to the input terminal of TC (5000+1000) and then calculate the corresponding temperature value according to the calculation formula:

$$4.18 + 2.26 * 10^{-2} * 6000 + 1.41 * 10^{-7} * 6000^2 + 1.50 * 10^{-11} * 6000^3 - 1.35 * 10^{-15} * 6000^4 = 146.3 \text{ } ^{\circ}\text{C}$$

(6) Custom RTD sensor type

When the Characterization Type selects Custom defined RTD, multiple sets of custom linear polynomials will appear. Fill in the appropriate polynomial coefficients and ranges to complete a custom TC type. You can refer to the custom TC method for setting.

(7) Multi-point linearization calibration

Taking into account the accuracy and error of the sensor, our temperature transmitter also provides a multi-point linearization calibration function. Provides 2-16 calibration points, which can be selected at will.

When selecting Calibration->User Calibration Table, a dialog box will pop up, and the user can add the data of multiple calibration points as required. This dialog box provides three functions: read table, write table and reset table. When writing the table, you must first enter the number of calibration points to be written, and select the number of calibration points in this way.

Table	
X1: 0	Y1: 0
X2: 6	Y2: 6
X3: 12	Y3: 12
X4: 18	Y4: 18
X5: 24	Y5: 24
X6: 30	Y6: 30
X7: 36	Y7: 36
X8: 42	Y8: 42
X9: 48	Y9: 48
X10: 54	Y10: 54
X11: 60	Y11: 60
X12: 66	Y12: 66
X13: 72	Y13: 72
X14: 78	Y14: 78
X15: 84	Y15: 84
X16: 90	Y16: 90

Figure 3.12 User multi-point calibration

(8) Two-point linearization calibration

The temperature transmitter has been rigorously calibrated before leaving the factory. Generally, the user does not need to calibrate it again. The user uses Lower Calibration Point, Upper Calibration Point and Calibration Unit

parameters to achieve two-point linearization calibration.

The steps are as follows:

- 1) Open the PDM software, after the configuration is complete, select Device -> Calibration -> Lower / Upper to call up the temperature calibration page.
- 2) Determine the sensor type and set the Characterization Type and Input Range and Mode parameters. Set the Calibration Unit parameter according to the sensor type. Currently, only three units of Celsius, Ohm and Millivolt are supported. Write parameters.
- 3) Provide the standard data of the channel to be calibrated through the standard source. After the input is stable, write the calibration data into the Upper Calibration Point or Lower Calibration Point parameters according to whether the operation is the upper or lower calibration. If no write error is prompted, it means calibration success. **Note that the written calibration data and the actual input channel data cannot have a large deviation, otherwise the calibration will fail.**

Note: When using Device -> Master Reset, the CPU of the instrument will be reset and the communication will be temporarily interrupted. This is a normal phenomenon, just reconnect.

3.3.6 Modify the main parameters of the device through GSD file

In the STEP7 hardware configuration interface, there are two ways to modify parameters:

- 1) Right-click the device, select properties, and configure the main parameters of the conversion block;
- 2) Right-click the AI in the Slot and select properties to configure the main parameters of the AI function block;

Note:

Call up the interface as shown in Figure 3.13 according to method 1, and modify the Parameterization parameter to DPV0+DPV1, and then the rest of the parameter modification will be effective. If you select DPV1 only, the modification of these two parts is invalid.

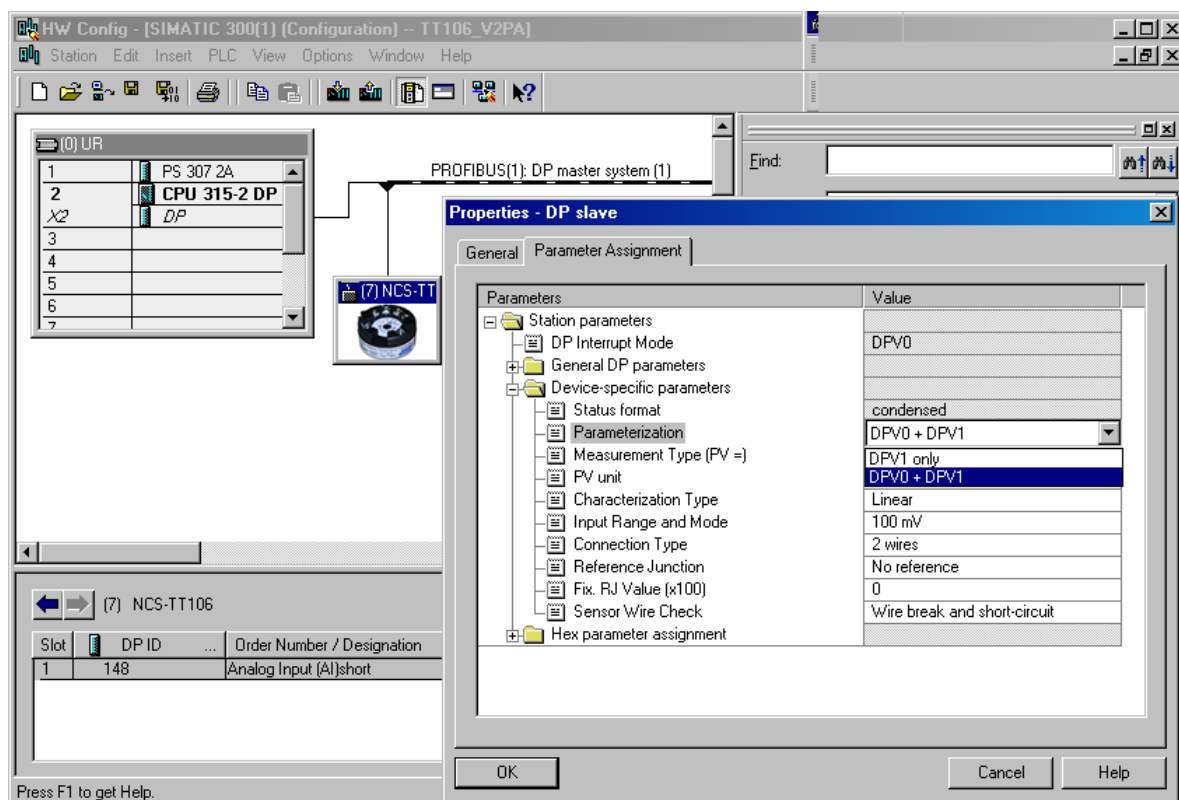

Figure 3.13 Modify device parameters

In the device parameter section, the parameters can be modified as shown in the table below, note that some parameters have magnifications:

Parameter	Name in GSD
PRIMARY_VALUE_UNIT	PV unit
LIN_TYPE	Characterization Type
INPUT_RANGE	Input Range and Mode
SENSOR_CONNECTION	Connection Type
RJ_TYPE	Reference Junction
EXTERNAL_RJ_VALUE	Fix. RJ Value (x100)
SENSOR_WIRE_CHECK_1	Sensor Wire Check

Among them, PV unit and Input Range and Mode must match correctly, otherwise, the device will report a parameterization error, causing the device to fail to enter the data exchange mode.

The correct matching method is as follows:

When Characterization Type is Linear, the parameters Input Range and Mode are valid;

When the parameter Input Range and Mode is 100 mV, the PV unit should be mV;

When the parameter Input Range and Mode is 0-500 Ohm or 0-4000 Ohm, the PV unit should be Ohm;

When the parameter Input Range and Mode is other configurable sensor types (thermal resistance, thermocouple), PV unit can be 4 temperature units (degC, degF, K, degR).

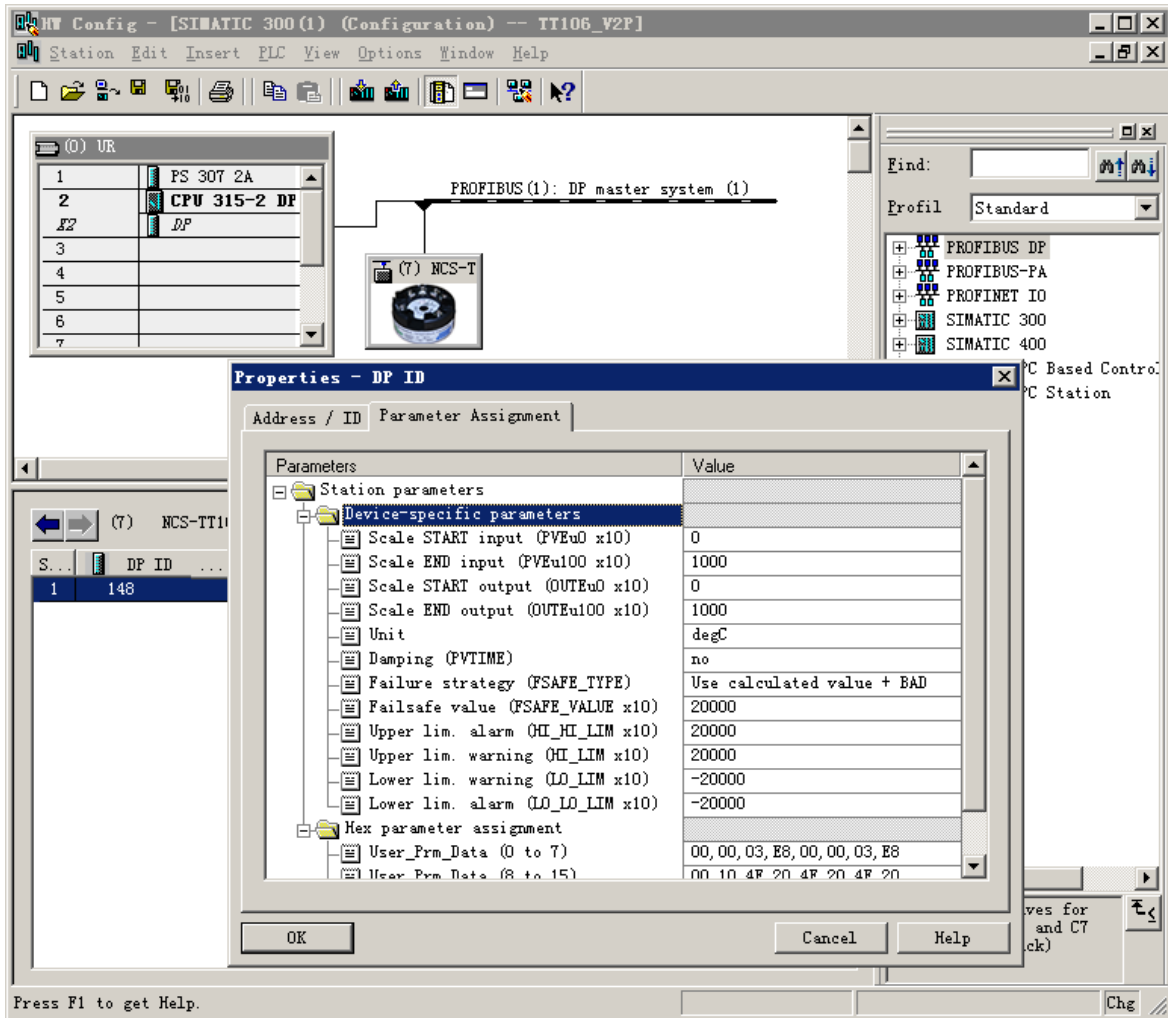

Figure 3.14 Modify AI function block parameters

In the parameter section of the AI function block, the parameters can be modified as shown in the table below. Note that some parameters have magnification:

Parameter	Name in GSD
PV_SCALE.EU_at_0%	Scale START input (PVEu0 x10)
PV_SCALE.EU_at_100%	Scale END input (PVEu100 x10)
OUT_SCALE.EU_at_0%	Scale START output (OUTEu0 x10)
OUT_SCALE.EU_at_100%	Scale END output (OUTEu100 x10)
OUT_SCALE.Units_Index	Unit
PV_FTIME	Damping (PVTIME)
FSAFE_TYPE	Failure strategy (FSAFE_TYPE)
FSAFE_VALUE	Failsafe value (FSAFE_VALUE x10)
HI_HI_LIM	Upper lim. alarm (HI_HI_LIM x10)
HI_LIM	Upper lim. warning (HI_LIM x10)

LO_LIM	Lower lim. warning (LO_LIM x10)
LO_LO_LIM	Lower lim. alarm (LO_LO_LIM x10)

4 Maintenance

Phenomenon	Solution
No communication	<p>Temperature Transmitter Connection Check the bus cable connection Check bus power polarity Check bus cable shield, whether it is single point earthing or not</p>
	<p>Bus power At the temperature transmitter end, the output voltage of the bus power supply should be between 9 and 32V. In addition, bus noise and ripple should meet the following requirements: 1) Peak-to-peak noise 16mV, 7 ~ 39kHz; 2) Peak-to-peak noise 2V, 47 ~ 63Hz, non-intrinsically safe environment; 3) Peak-to-peak noise 0.2V, 47 ~ 63Hz, intrinsically safe environment; 4) Peak-to-peak noise of 1.6V, 3.9M ~ 125MHz.</p>
	<p>Network Connection Check network topology structure Check terminal matcher and wiring Check the length of main trunk and branch</p>
	<p>Address Conflict The default address of PA temperature transmitter is 126 when it leaves the factory. If you do not modify the address, address conflicts may occur. When a conflict occurs, sometimes the conflicting device will go online with a temporary address. Sometimes it can't go online at all. You can power off the conflicting devices first, and then power on one by one until all go online.</p>
	<p>Temperature Transmitter Failure Replace the temperature transmitter with others for testing.</p>
Reading Error	<p>Temperature Module Connection Failure Check sensor short circuit, open circuit, and earthing. Check sensor</p>
	<p>Noise Disturb Adjust damping Check the house earthing Check if the terminal is moist Check the cable is away from the strong electromagnetic interference</p>
	<p>Software Configuration Check sensor type configuration Check function block parameter configuration</p>
	<p>Temperature Transmitter Failure Replace the temperature module with others for testing.</p>

5 Technical specifications

5.1 Basic parameters

Bus interface	Profibus PA
Bus power	9~32VDC 9~17.5VDC (Intrinsically safe)
Input signal	Thermal resistance: Pt100、Pt1000、CU50、CU100 Resistance signal: (0~500)Ω、(0~4000)Ω Thermocouple: B、E、J、K、N、R、S、T mV signal: (-100~100) mV
Number of channels	Single channel
Start time	≤5s
Update time	RTD 2-wire,4-wire: 0.7s RTD 3-wire: 1.4s TC :0.75s
Operating temperature	-40~85°C
Storage temperature	-40~85°C
Humidity range	5~95%RH
Electrical isolation	1000VAC
Voltage effect	±0.005%/V
Protection level	Terminal IP00 ;Housing IP40
Explosion-proof	Ex ia IIC T4 Ga
EMC	GB/T 18268.1-2010 Immunity requirements for industrial sites in "Electromagnetic Compatibility Requirements for Electrical Equipment for Measurement, Control, and Laboratory Use Part 1: General Requirements" GB/T 18268.25-2010 "Electromagnetic compatibility requirements for electrical equipment for measurement, control and laboratory use-Part 25: Special requirements. Test configuration, working conditions and performance criteria for field devices whose interfaces conform to IEC 61784-1, CP 3/2"

5.2 Thermal resistance technical index

- RTD Normal temperature accuracy index (25°C)

Signal type	Range	Recommended range (°C)	Accuracy	Temperature drift (per °C)
Resistance signal	0~500Ω	0~500Ω	±0.04Ω	±0.001Ω
	0~4000Ω	0~4000Ω	±0.35Ω	±0.015Ω
PT100	-200~850°C	-200~850°C	±0.15°C	±0.003°C
PT1000	-200~850°C	-200~850°C	±0.15°C	±0.005°C
CU50	-50~150°C	-50~150°C	±0.15°C	±0.005°C
CU100	-50~150°C	-50~150°C	±0.10°C	±0.003°C

● RTD Other technical indicators

Wiring	2、3、4
Common mode rejection ratio	≥70dB (50Hz & 60HZ)
Differential mode rejection ratio	≥70dB (50Hz & 60HZ)

5.3 Thermocouple technical indicators

● Thermocouple room temperature accuracy index (25°C)

Signal type	Range	Recommended range (°C)	Accuracy	Temperature drift (per °C)
mV	-100mV~+100mV	-100mV~+100mV	±0.025mV	±0.001 mV
B	0°C~1820°C	500°C~1810°C	±0.77°C	±0.050°C
E	-270°C~1000°C	-200°C~1000°C	±0.20°C	±0.025°C
J	-210°C~1200°C	-190°C~1200°C	±0.35°C	±0.01°C
K	-270°C~1372°C	-200°C~1372°C	±0.40°C	±0.025°C
N	-270°C~1300°C	-190°C~1300°C	±0.50°C	±0.015°C
R	-50°C~1768°C	0°C~1768°C	±0.75°C	±0.023°C
S	-50°C~1768°C	0°C~1768°C	±0.70°C	±0.023°C
T	-270°C~400°C	-200°C~400°C	±0.35°C	±0.015°C

● Other technical indicators of thermocouple

Compensation accuracy	±0.5°C
Sensor type	B, E, J, N, K, R, S, T; -100mV~+100mV Voltage
Common mode rejection ratio	≥70dB (50Hz & 60HZ)
Differential mode rejection ratio	≥70dB (50Hz & 60HZ)

5.4 Physical characteristics

Size	NCS-TT106P: φ45*23mm; NCS-TT106P-R1: 110*99*22.5mm
Housing material	Nylon



Microcyber Corporation

Web:<http://www.microcyber.cn/en>

Add: 17-8 Wensu Street, Hunnan New District,
Shenyang, China 110179

Tel: 0086-24-31217278 / 31217280

Fax: 0086-24-31217293

Email: sales@microcyber.cn